

# EMBEDDED SOLAR ROAD MARKERS

IDEA CHOICE FOR CENTERLINE USAGE

---

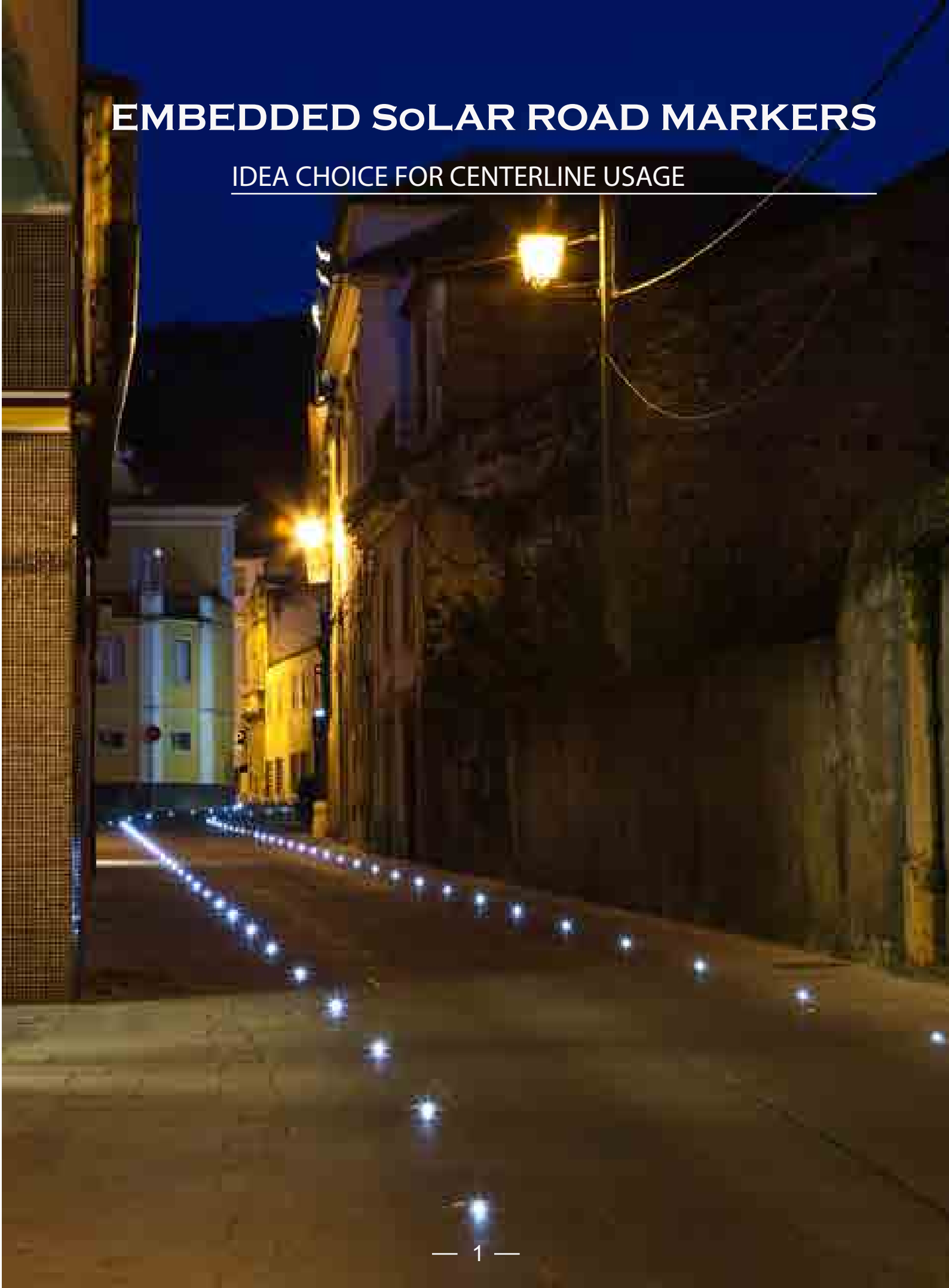

# EMBEDDED SOLAR ROAD MARKERS

ONLY- 3.5mm ABOVE THE ROAD SURFACE



**SRS0150A**  
Dia.50 MM  
1 LED on the top,  
360 degree illuminated



**SRS0180A**  
Dia.80 MM  
1 LED on the top,  
360 degree illuminated



**SRS01100A**  
Dia.50 MM  
1 LED on the top,  
360 degree illuminated

## ***Applications:***

Cycleway  
Motorway Centerline  
Crosswalks  
Decorative Areas  
...



**SRS0180B**  
Dia.80 MM  
2 LED on the top  
Double ways illuminated

## ***Applications:***

Cycleway  
Motorway Centerline  
Crosswalks  
Decorative Areas  
...  
*Used for  
Double ways illuminated*

## Why Benedrive's design is your better choice:

1. Over-mobile, even for snow plough, only 3mm over the road surface.
2. Products Depth: 20-30mm, Installation is much easier and cost much less. And Could be used for all types of Highways and country road. (Other designs' depth is about 100mm, could not used for some highways and country road which depth is very limited. Less than 60mm.)
3. Solid inside, much more durable than others, which are empty inside.
4. Unit cost much lower than other embedded markers.



## Special Designs:



Special installation part, stop the marker sink into the installation hole, and also easy to broken and take away by the vehicles' wheels



Bliges stop the markers' revolving



Special dust proof design

## Application Areas Introduction:

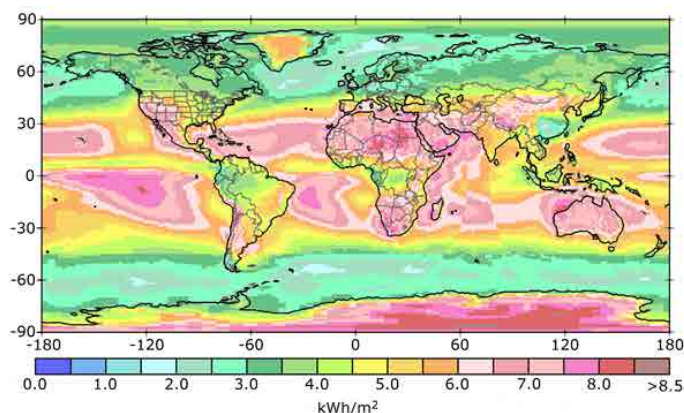

>3.5: Dia.50mm products

>2.5: Dia.80mm products

>1.5: Dia.100mm products

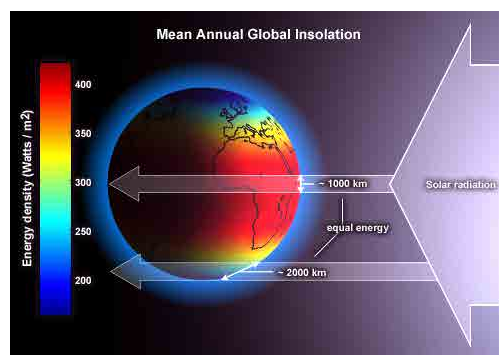

# Item No: SRS0150A

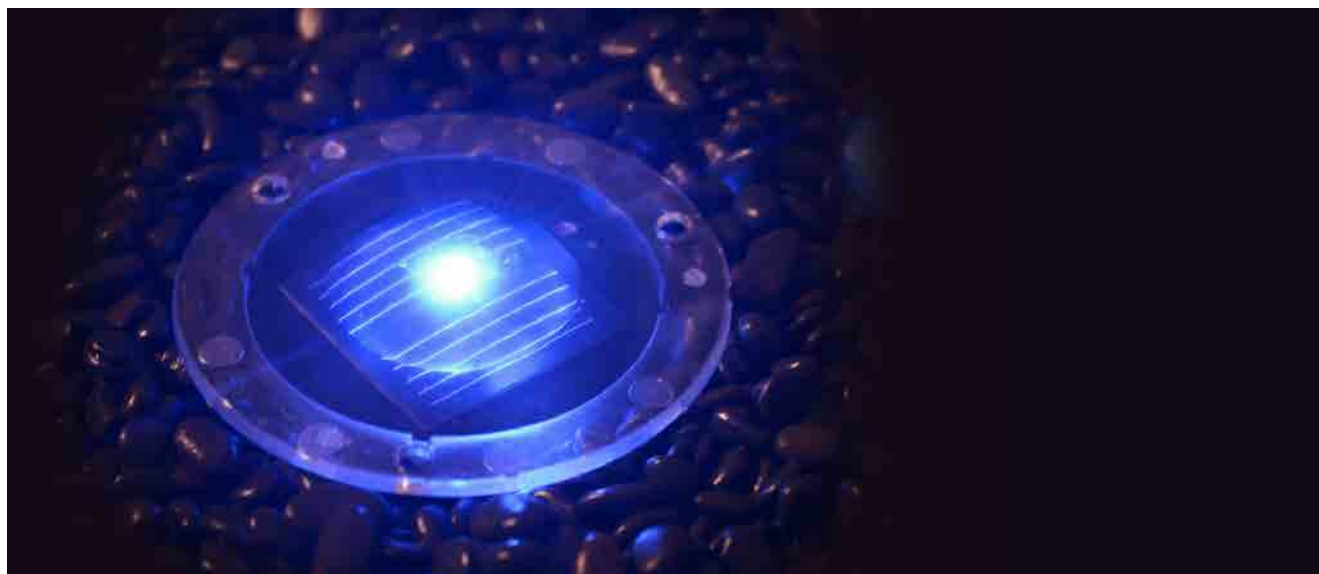

### Applications :

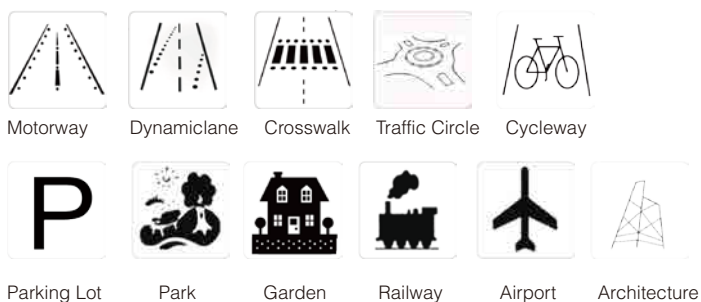

### Key Feature

1. Special reflector design: 360 Degree illuminates.
2. Perfect water proof - IP 68
3. Well fit the road surface, especially for cycle ways, only 3.5mm over the road surface, snow ploughable

### Specification

1. Size: Dia.50mm, Height: 26mm
2. Working type: Steady or flashing optional  
flashing Rate customized available
3. Start working, from 500 Lux
4. Material: PC
5. Solar Cell type: Mono crystalline
6. Work temperature: -20 C ~ +70. C
7. Ultra bright 5mm LEDs, use life over 100 000 hours
8. LED Color: White, yellow, red, blue, green
9. Package: 2pcs in one box 12pcs/Carton  
Carton size: 220mm x 220mm X 125mm

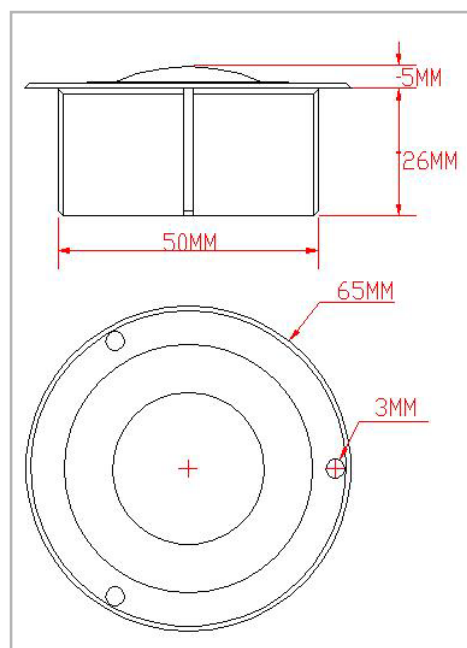

# Item No: SRS0180A



### Applications :



### Key Feature

1. Special reflector design: 360 Degree illuminates.
2. High quality battery, use life over 5 years
3. Perfect water proof - IP 68
4. Well fit the road surface, especially for cycle ways, only 3.5mm over the road surface, snow ploughable

### Specification

1. Size: Dia.80mm, Height: 30mm
2. Working type: Steady or flashing optional  
flashing Rate customized available
3. Start working, from 500 Lux
4. Material: PC
5. Solar Cell type: Mono crystalline
6. Work temperature: -20 C ~ +70. C
7. Ultra bright  $\Phi$ 5mm LEDs, use life over 100 000 hours
8. LED Color: White, yellow, red, blue, green
9. Package: 2pcs in one box 12pcs/Carton  
Carton size: 220mm x 220mm X 125mm

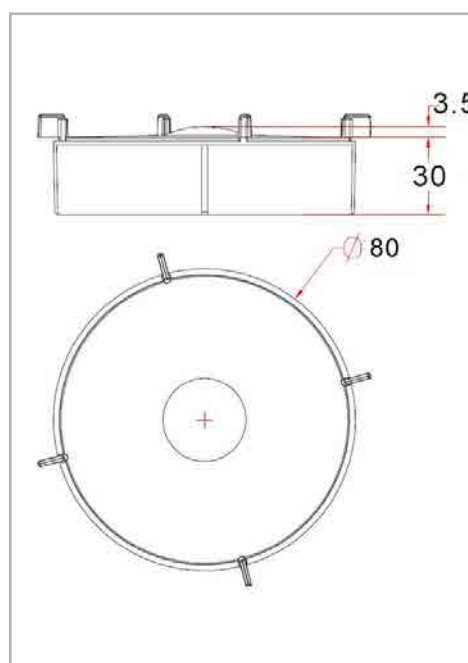



# Item No: SRS01100A



### Applications :



### Key Feature

1. Special reflector design: 360 Degree illuminates.
2. High quality battery, use life over 5 years
3. Perfect water proof - IP 68
4. Well fit the road surface, especially for cycle ways, only 3.5mm over the road surface, snow ploughable

### Specification

1. Size: Dia.100mm, Height: 26mm
2. Working type: Steady or flashing optional  
flashing Rate customized available
3. Start working, from 500 Lux
4. Material: PC
5. Solar Cell type: Mono crystalline
6. Work temperature: -20 C ~ +70. C
7. Ultra bright  $\Phi$ 5mm LEDs, use life over 100 000 hours
8. LED Color: White, yellow, red, blue, green
9. Package: 2pcs in one box 12pcs/Carton  
Carton size: 220mm x 220mm X 125mm

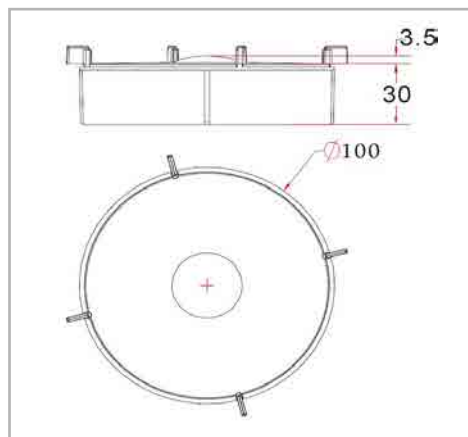

Item No: SRS0180B



**Applications :**



**Key Feature**

1. Special reflector design: 1direction,2 directions (optional)
2. Well fit the road surface, especially for cycle ways, only 3.5mm over the road surface
3. Perfect water proof: IP68
4. High quality battery, long life over 5 years

**Specification**

1. Size: Dia.80mm, Height: 26mm
2. Working type: Steady or flashing optional  
flashing Rate customized available
3. Start working, from 500 Lux
4. Material: PC
5. Solar Cell type: Mono crystalline
6. Work temperature: -20 C ~ +70. C
7. Ultra bright  $\Phi$ 5mm LEDs, use life over 100 000 hours
8. LED Color: White, yellow, red, blue, green
9. Package: 2pcs in one box 12pcs/Cartron  
Carton size: 220mm x 220mm X 125mm

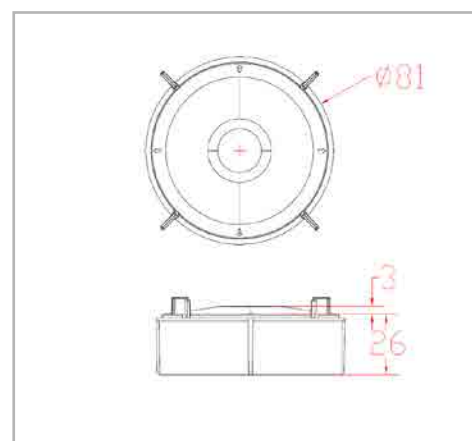

## Installation Instructions

1. Drill a hole, Depth: 30mm, normally 5 MM more than the depth , Diameter according to each model's size: 50, 80, 100
2. Clean and Dry the hole
3. Fill in glue, till 1/3 of the Depth
4. Put the marker in wait the glue dry out

Installation for the ones with installation rings

Instllation for the ones with installation pins

## Item No: CCM 02X Concrete core machines



Concrete core machine:

- 1、 Max drill dia. :  $\phi$  150mm
- 2、 Max drill depth: 400mm
- 3、 Power: 2.5kw
- 4、 Voltage: 220v
- 5、 Size: 470x280x880mm



Concrete core machine:

- 1、 Max drill diameter:  $\Phi$  200mm
- 2、 Max drill depth:  $\Phi$  400mm
- 3、 Power: 10p
- 4、 Start: Handle
- 5、 Main rotation rate: 1100-1500/min
- 6、 Weight: 120kg
- 7、 Size: 1060x870x1300mm

Special drill bit of highway and railway engineering (red types fit our markers): CCM020\*\*

Bit Diameter	Effective Length (mm)	Drill Tooth
Specifications (mm)	Drill Tooth Numbers	
$\Phi$ 51mm	2" 350(400)	22x9x(3.5)4 5
$\Phi$ 89mm	3-1/2" 350(400)	22x9x(3.5)4 8
$\Phi$ 102mm	4" 350(400)	22x9x(3.5)4 9

Other sizes customizedable



## Item No: CCM 01X



Road cutter : CCM01\*\*  
 Road cutter:Max cutting depth: 180mm  
 Bit diameter:  $\Phi$  400-500mm  
 Water volume: 40L

Road cutter:  
 Max cutting depth: 170mm  
 Diesel oil machine power: S185.8PS  
 Max speed: 2200r/min  
 Cutting bit speed: 36m/50x45m/s  
 Water volume: 55L



Concrete core machine:  
 Operating mode: Self pressure  
 Drilling diameter:  $\Phi$ 600- $\Phi$ 1200mm  
 Drilling Depth: 15meters  
 Rotation Angle: 360degree  
 Output torque : 26000N·m  
 Hydraulic system pressure: 20Mpa  
 Rotary speed: 25-30r/min  
 Engine Model: 6105/4108turbocharging  
 engine power /rotate speed: 120Kw/2200r  
 Outlet size mm: 10500x2500x3200  
 Whole weight: 15T